

- ▶ Timer multifunctional
- ▶ 6 Functions
- ▶ 7 time ranges
- ▶ Wide supply voltage range
- ▶ 2 change over contacts
- ▶ Width 22.5 mm
- ▶ Industrial design



## Technical data

### 1. Functions

Ip	Asymmetric flasher pause first
Ii	Asymmetric flasher pulse first
ER	ON delay and OFF delay with control input
EWu	ON delay and single shot leading edge with control input
EWs	ON delay single shot leading edge voltage controlled
WsWa	Single shot leading and single shot trailing edge with control contact

### 2. Time ranges

Time range	Adjustment range	
1s	50ms	1s
10s	500ms	10s
1min	3s	1min
10min	30s	10min
1h	3min	1h
10h	30min	10h
100h	5h	100h

### 3. Indication

Green LED U/t ON:	indication of supply voltage
Green LED U/t slow flashing:	indication of time period t1
Green LED U/t fast flashing:	indication of time period t2
Yellow LED R ON/OFF:	indication of relay output

### 4. Mechanical design

Self-extinguishing plastic housing, IP rating IP40  
 Mounted DIN-rail TS 35 according to EN 50022  
 Mounting position: any  
 Shockproof terminal connection according to VBG 4 (PZ1 required), IP rating IP20  
 Tightening torque: max. 1Nm  
 Terminal capacity:  
 1 x 0.5 to 2.5mm<sup>2</sup> with/without multicore cable end  
 1 x 4mm<sup>2</sup> without multicore cable end  
 2 x 0.5 to 1.5mm<sup>2</sup> with/without multicore cable end  
 2 x 2.5mm<sup>2</sup> flexible without multicore cable end

### 5. Input circuit

Supply voltage: terminals A1(+)-A2  
 Types G2Z..12-240VAC/DC: 12 to 240V AC/DC  
 Tolerance: 12V-10% to 240V+10%  
 Rated consumption: 6VA (2W)  
 Rated frequency: AC 48 to 63Hz  
 Duty cycle: 100%  
 Reset time: 100ms  
 Residual ripple of DC: 10%  
 Drop out voltage: >30% minimum rated supply voltage  
 Overvoltage category: III (according to IEC 60664-1)  
 Rated surge voltage: 4kV

### 6. Output circuit

2 potential free change over contacts  
 Rated surge 250V AC  
 Switching capacity (distance <5mm):  
 750VA (3A / 250V AC)  
 Switching capacity (distance >5mm):  
 1250V (5A / 250V AC)

Fusing: 5A fast acting  
 Mechanical life: 20 x 10<sup>6</sup> operations  
 Electrical life: 2 x 10<sup>5</sup> operations  
 at 1000VA resistive load  
 max. 60/min at 100VA resistive load  
 max. 6/min at 1000VA resistive load  
 (according to IEC 947-5-1)  
 Switching frequency:  
 III. (according to IEC 60664-1)  
 Overvoltage category: 4kV  
 Rated surge voltage: 4kV

### 7. Control contact

Input not potential free: terminals A1-B1  
 Loadable: yes  
 Max. line length: 10m  
 Trigger level (sensitivity): automatic adaption to supply voltage  
 Min. control pulse length: DC 50 ms / AC 100 ms

### 8. Accuracy

Base accuracy: ±1% of maximum scale value  
 Adjusting accuracy: <5% of maximum scale value  
 Repetition accuracy: <0.5% or ±5ms  
 Voltage influence: -  
 Temperature influence: ≤0.01% / °C

### 9. Ambient conditions

Ambient temperature: -25 to +55°C (according to IEC 68-1)  
 Storage temperature: -25 to +70°C  
 Transport temperature: -25 to +70°C  
 Relative humidity: 15% to 85%  
 (according to IEC 721-3-3 Klasse 3K3)  
 Pollution degree: 3 (according to IEC 664-1)  
 Vibration resistance: 10 to 55 Hz 0.35mm  
 (according to IEC 68-2-6)  
 Shock resistance: 15g 11ms  
 (according to IEC 68-2-27)

### 10. Dimensions

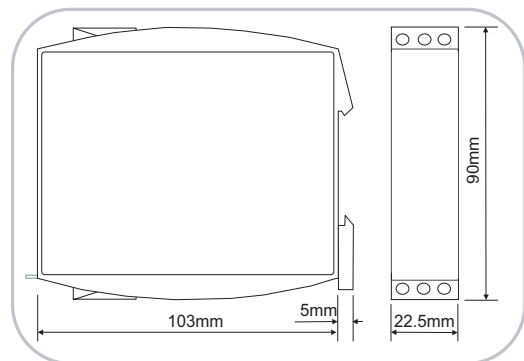

## Functions

The function has to be set before connecting the relay to the supply voltage.

### Asymmetric flasher pause first (Ip)

When the supply voltage U is applied, the set interval t1 begins (green LED U/t flashes slowly). After the interval t1 has expired, the output relay R switches into on-position (yellow LED illuminated) and the set interval t2 begins (green LED U/t flashes fast). After the interval t2 has expired, the output relay switches into off-position (yellow LED not illuminated).

The output relay is triggered at the ratio of t1:t2 until the supply voltage is interrupted.

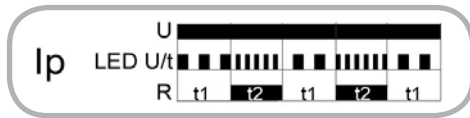

### Asymmetric flasher pulse first (Ii)

When the supply voltage U is applied, the output relay R switches into on-position (yellow LED illuminated) and the set interval t1 begins (green LED U/t flashes slowly). After the interval t1 has expired, the output relay switches into off-position (yellow LED not illuminated) and the set interval t2 begins (green LED U/t flashes fast). After the interval t2 has expired, the output relay switches into on-position (yellow LED illuminated). The output relay is triggered at the ratio of t1:t2 until the supply voltage is interrupted.

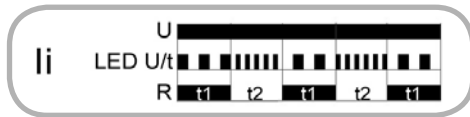

### ON delay and OFF delay with control input (ER)

The supply voltage U must be constantly applied to the device (green LED U/t illuminated).

When the control contact S is closed, the set interval t1 begins (green LED U/t flashes slowly). After the interval t1 has expired (green LED U/t illuminated), the output relay R switches into on-position (yellow LED illuminated). If the control contact is opened, the set interval t2 begins (green LED U/t flashes fast). After the interval t2 has expired (green LED U/t illuminated) the output relay switches into off-position (yellow LED not illuminated).

If the control contact is closed during timing of t2 the expired interval is erased, and the off delay restart next time the control contact is opened.



### ON delay and single shot leading edge with control input (EWs)

The supply voltage U must be constantly applied to the device (green LED U/t illuminated).

When the control contact S is closed, the set interval t1 begins (green LED U/t flashes slowly). After the interval t1 has expired (green LED U/t illuminated), the output relay R switches into on-position (yellow LED illuminated) and the set interval t2 begins (green LED U/t flashes fast). After the interval t2 has expired (green LED U/t illuminated) the output relay switches into off-position (yellow LED not illuminated). During the interval, the control contact can be operated any number of times.

A further cycle can only be started when the cycle run has been completed.

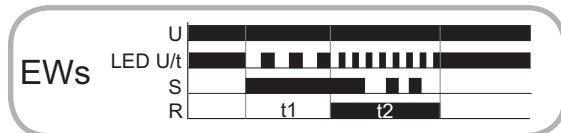

### ON delay and single shot leading edge voltage controlled (EWu)

When the supply voltage U is applied, the set interval t1 begins (green LED U/t flashes slowly). After the interval t1 has expired the output relay R switches into on-position (yellow LED illuminated) and the set interval t2 begins (green LED U/t flashes fast). After the interval t2 has expired (green LED U/t illuminated) the output relay switches into off-position (yellow LED not illuminated).

If the supply voltage is interrupted before the interval t1+t2 has expired, the interval already expired is erased and is restarted when the supply voltage is next applied.

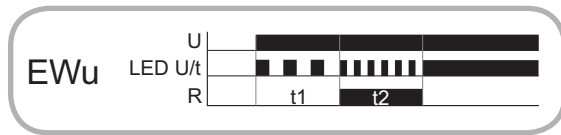

### Single shot leading and single shot trailing edge with control contact (WsWa)

The supply voltage U must be constantly applied to the device (green LED U/t illuminated).

When the control contact S is closed, the output relay R switches into on-position (yellow LED illuminated) and the set interval t1 begins (green LED U/t flashes slowly). After the interval t1 has expired, the output relay R switches into off-position (yellow LED not illuminated). If the control contact is opened, the output relay again switches into on-position (yellow LED illuminated) and the set interval t2 begins (green LED U/t flashes fast). After the interval t2 has expired the output relay switches into off-position (yellow LED not illuminated). If the control contact opens before the interval t1 has expired, t1 continuous according to the adjusted period and the single shot trailing edge impulse (t2) follows directly after t1. During the interval, the control contact can be operated any number of times.

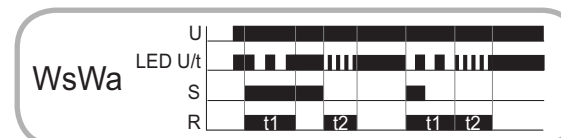

## Connections

with control contact

without control contact

