

- ▶ Low voltage measurement
- ▶ Reinforced insulation of the measuring circuit
- ▶ Measured value transmitting via standard bus
- ▶ Modular monitoring system
- ▶ Measured range 10V for standard signal
- ▶ Measured ranges 60mV and 150mV for shunt measurement
- ▶ Width 22.5mm
- ▶ Industrial design



Technical data

1. Functions

WatchDog pro modul for low voltage measurement.

2. Address adjustment

Address range: 1-99
Deactivation (Off): address 0

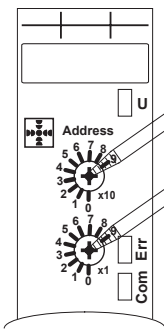

Potentiometer 1:
To adjust the **DECADES**

Potentiometer 2:
To adjust the **UNITS**

e.g.: the address **43** will be adjusted as follows:

Potentiometer 1 on position **4**
Potentiometer 2 on position **3**

3. Indicators

Green LED U ON: module is supplied via local interface
Yellow LED Com ON / flashes: data exchange over standard bus is in progress
Red LED Err ON: indication of failure

4. Mechanical design

Self-extinguishing plastic housing, IP rating IP20
Mounted on DIN-rail TS 35 according to EN 50022
Mounting position: any
Shockproof terminal connection according to VBG 4 (PZ1 required), IP rating IP20
Tightening torque: max. 1Nm
Terminal capacity:
1 x 0.5 to 2.5mm² with/without multicore cable end
1 x 4mm² without multicore cable end
2 x 0.5 to 1.5mm² with/without multicore cable end
2 x 2.5mm² flexible without multicore cable end

5. Supply

Rated voltage: 24V DC from local interface
Tolerance: -17.5% to +16.5%
Rated consumption: 1W
Rated current: 37mA
Max. supply current: 50mA
Ripple and noise: < 150mV_{PP}
Duty cycle: 100%
Start-up time: 2.2s typ.
Drop-out voltage: > 60% of supply voltage

6. Businterface

Standard bus:

Data link: RS485; yellow LED Com ON
Interface parameter: 115.2kBd, 9 bits data
Number of extension modules:
Local interface: 24* (width 22.5mm)

* dependent on the max. permissible current through local interface of the Central Unit (CU)
(additional extension is possible by the remote bus!)

7. Isolation

Overvoltage category: III (in accordance with IEC 60664-1)
Rated surge voltage: 6kV between input circuit and local interface

8. Measuring circuit

Measured variable: DC or AC Sinus (16.6 to 400Hz)
Measured value: U_{eff}
Measuring input:
60mV AC/DC terminals E - F1 (+) (for shunt measurement)
150mV AC/DC terminals E - F2 (+) (for shunt measurement)
10V AC/DC terminals E - F3 (+)
Overload capacity:
60mV AC/DC 0.5V_{eff}
150mV AC/DC 1.0V_{eff}
10V AC/DC 30V_{eff}
Input resistance:
60mV AC/DC 47Ω
150mV AC/DC 82Ω
10V AC/DC 191kΩ
External shunt in conjunction with measuring line:
60mV AC/DC <0.25Ω
150mV AC/DC <0.40Ω

9. Accuracy

Base accuracy: ± 5% of upper range value
Frequency response: -10% to +5% (16.6 to 400Hz)
Repetition accuracy: ≤ 2%
Voltage influence: ≤ 0.5%
Temperature influence: ≤ 0.1% / °C

10. Ambient conditions

Ambient temperature: -25 to +55°C (in accordance with IEC 68-1)
-25 to +40°C (in accordance with UL 508)
Storage temperature: -25 to +70°C
Transport temperature: -25 to +70°C
Relative humidity: 15% to 85%
(in accordance with IEC 60721-3-3 class 3K3)
Absolute humidity: 1g to 25g H₂O/m³
(in accordance with IEC 60721-3-3 class 3K3)
Pollution degree: 2 (in accordance with IEC 60664-1)
Vibration resistance: 10 to 55Hz 0.35mm
(in accordance with IEC 68-2-6)
Shock resistance: 15g 11ms (in accordance with IEC 68-2-27)

Operator accessibility of clamps and connectors

The table shows which terminals and connectors can be touched by the operator during normal operation.

Nr.	Type	Terminal	Touchable
1	AI	Communication interface for local input-/output-extension device	YES
2	Ar	Communication interface for remote input-/output unit	YES
3	Be	Open communication interface, open to external devices as well	YES
4	Bi	Internal communication interface for peripheral modules	NO
5	C	Interface for digital and analog input signals	NO
6	D	Interface for digital and analog output signals	NO
7	E	Serial or parallel communication interface for data communication with external devices	YES
8	F	Terminal for line power supply	NO
9	H	Functional Earth terminal	YES
10	J	Input/output interface for power supply of sensors and actuators	NO
11	K	Interface for auxiliary supply output and auxiliary supply input	NO

1-phase voltage measurement: G2UI1 10V - Definition of circuits:

Name	Type	Nr.	Terminals related to the Circuit
Voltage inputs	C	5	E, F1, F2, F3
Local interface	AI	1	LI Box header; LI plug connector with ribbon cable

Connections

Measured range 60mV AC/DC

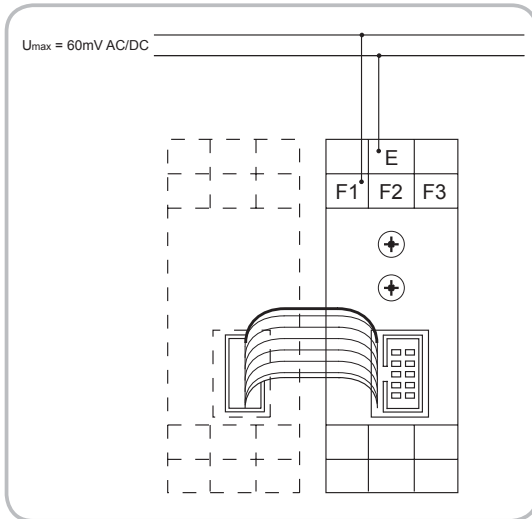

Measured range 150mV AC/DC

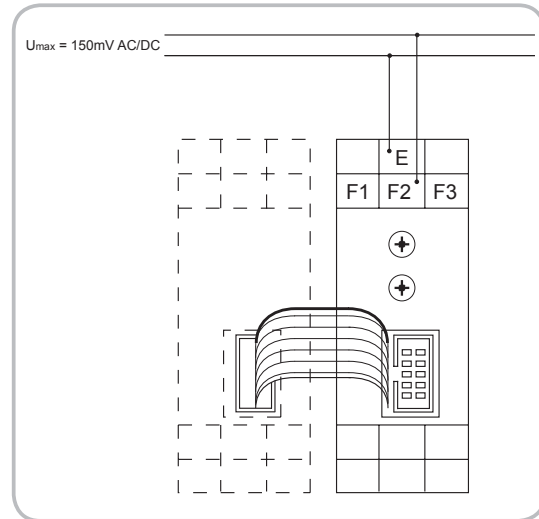

Measured range 10V AC/DC

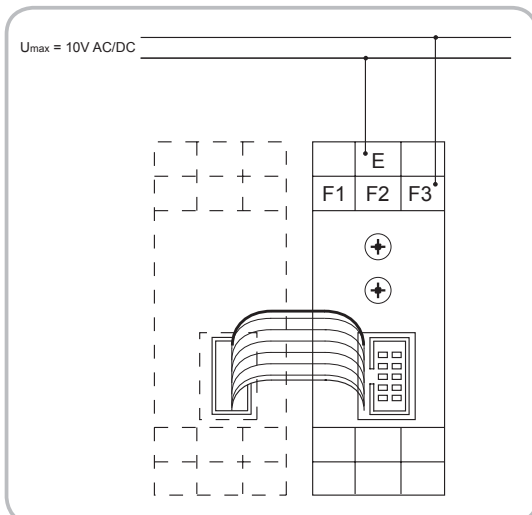

Dimensions

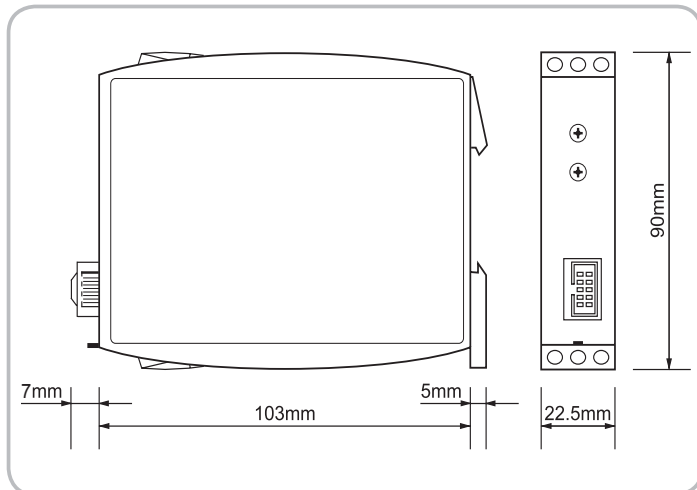

Ordering information

Type	Address range	LEDs	Part Nr. (PQ 1)
G2UI1 10V	1 to 99	U, Err, Com	2500050