

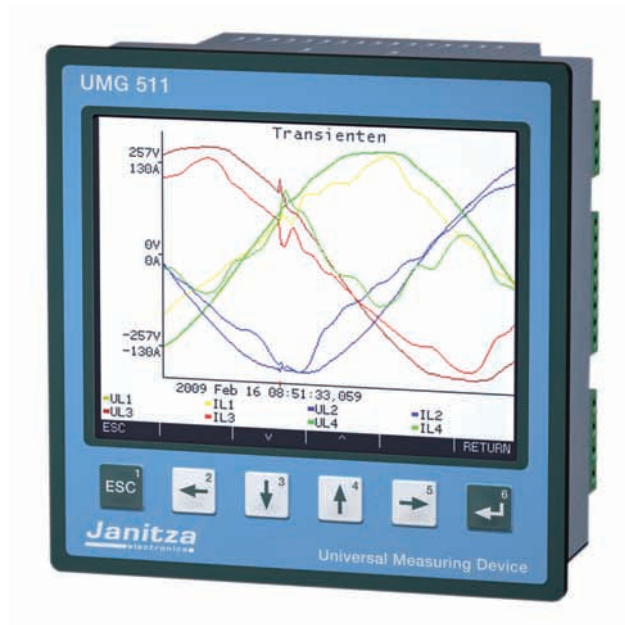

Power quality- analyser

according to EN 50160



Power quality analyser according to EN 50160

The UMG 511 power quality analyser is particularly suitable for monitoring power quality according to standards such as the EN 50160. All power quality parameters are collected and analysed e.g. flicker, short term interruptions with fault recorder function, transients, harmonics up to the 63rd and inrush currents etc. Extensive communication possibilities e.g. RS 485 Modbus, Profibus, Ethernet (TCP/IP), BACnet, http, FTP, SMTP, SNMP, DNS ... allow cost effective and rapid integration in existing communication networks. Worldwide access to the embedded web server can be gained through a web browser. The GridVis software included in the content of delivery allows extensive analysis just by the click of a button.

Areas of application

- Continuous monitoring of the power quality e.g. EN 50160
- Ethernet gateway for subordinate measurement points
- Analysis of electrical faults for network problems
- Monitoring of the internal distribution network according to EN 61000-4-7, 4-15, 4-30
- Report generator for EN 50160 analysis
- Remote control

Power quality analyser

Power quality analyser



UMG 511 Power quality analyser

Added value with additional functions

The UMG 511 power quality analyser serves for the purpose of continuous monitoring of the power quality e.g. in accordance with EN 50160. This serves for the purpose of monitoring the supply power quality from the energy supply side. The UMG 511 can also be used in applications for failure analysis on the consumer side and is also used as a preventative measure for network perturbations. A rapid, cost-optimised and reliable communication system can be developed through the Ethernet connection. The instrument's own homepage offers you the opportunity to call up the data or configure the instrument directly using the embedded web server.

The large number of digital inputs and outputs offer a variety of communication systems possibilities and allows connection to PLC systems and independent control tasks. The GridVis analysis software represents a fundamental part of the standard delivery. The GridVis can be used to practically trigger analysis in accordance with EN 50160 with the click of a button. The presentation of online data and the analysis of historical data is also a benefit for finding the root cause of network problems.



Main features

- Measurement of power quality according to **DIN EN 61000-4-30**
- **Measuring method as well as accuracy is class A**
- Fourier analysis **1st to 63rd** harmonic for U-LN, U-LL, I, P (consumption/supply) and Q (ind./cap.)
- Measurement of harmonics and interharmonics (U-LN, U-LL, I) according to **DIN EN 61000-4-7**
- Analysis and evaluation according to **DIN EN 50160** with the contained programming and analysis software GridVis
- Flicker measurement according to **DIN EN 61000-4-15**
- Measurement in TN and TT grids (500V CATIII)
- 4 voltage measuring inputs, 4 current measuring inputs
- **Continuous sampling of voltage and current inputs with 20kHz**
- Recording of more than 2000 different measurement parameter per measuring cycle (200ms)
- Detection of transients >50µs and storage with up to 16.000 samples
- Data logger / Event memory (256MB Flashdisk)
- 8 digital inputs and 5 digital outputs
- Profibus DP/V0 alternatively RS 485 (Modbus RTU, Modbus-Master, optional **BACnet**)
- **Ethernet** (Web-Server, E-Mail, optional BACnet)
- Programming of customer specific applications in Jasic

Applications

The power quality analyser which is equipped with 4 current and voltage inputs collects and digitalises the effective values (True RMS) from currents and voltages in 40-70Hz (15-440Hz) networks. The integrated microprocessor calculates the electrical parameters from the sampling values. The relevant voltage can be defined as a phase-neutral or a phase-phase voltage for measurement in a three-phase system. The voltage serves the UMG 511 as a reference voltage for harmonic measurement, transient and event recording and for the flicker meter. A nominal current can be set using this for the measurement of electrical current events. The 4th current and voltage input represents a separate measurement system. However, it is generally used for measuring the current in the neutral or PE conductor or used for measuring a voltage difference between N and PE.

Scope of operation

Display examples

The backlit graphical display (5,7") of the UMG 511 enables the presentation of measurement values in numerical form, as a bar chart or as a line graph. Selected displays can automatically be displayed in alternation (automatic display rotation). The instrument is programmed using userfriendly clear text menus or the GridVis software.

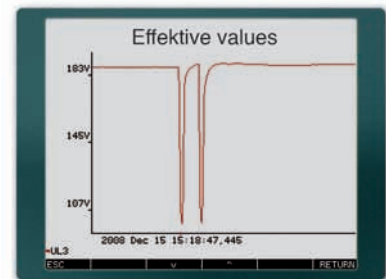
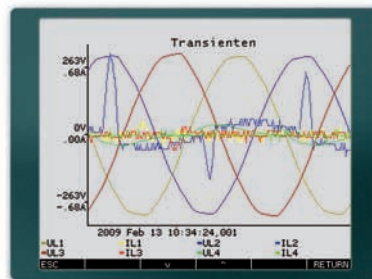
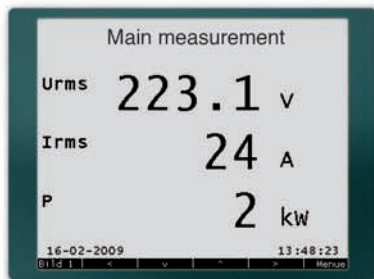
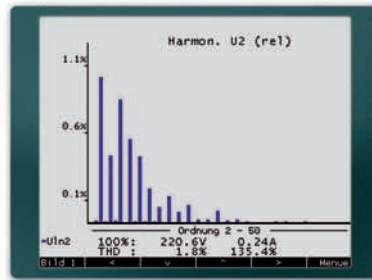
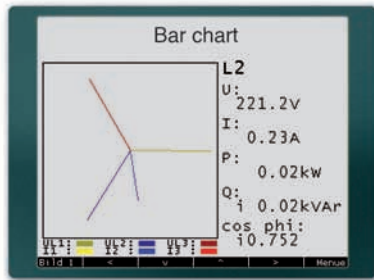

Example of a UMG 511 connection illustration

Measurement in a four-phase network with main measurement and auxiliary measurement

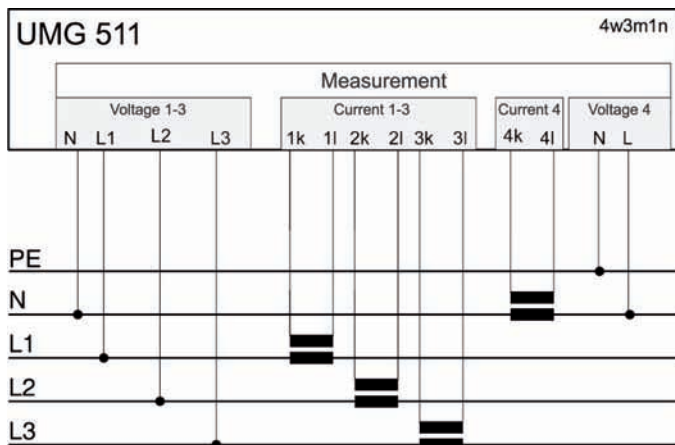

Main measurement

The UMG 511 has 4 measurement channels for current and voltage. The first three channels (main measurement) are intended for use in a three-phase system.

Auxiliary measurement

The auxiliary measurement can be used for measurement in a single-phase or symmetrical three-phase system. Alternatively, the current input can be allocated to the three-phase system of the main measurement for measuring the neutral-conductor current. For example, the voltage input could then be used for recording the voltage between the neutral conductor and PE. The auxiliary measurement provides all measurement parameters like in the main measurement (current, voltage, power, harmonics, transients, events and flicker).



Digital inputs and outputs

The 8 digital inputs of the instrument can either be used for tariff switchover, for synchronisation, to start the recording, or as datalogger for other meter inputs for pulses. There are 8 programmable comparators available which can be allocated up to 4 measurement parameters as a limit value comparator. The digital outputs can also be programmed as a signal output for transients, events or as a pulse output.

Interfaces

- RS485 protocols: Profibus DP or Modbus / RTU, Modbus-Gateway and BACnet
- Fast Ethernet 10/100Base-TX protocols: HTTP, NTP, Modbus TCP, Modbus over TCP, DHCP und BACnet.

The measurement values and recorded data can be called up using the Ethernet (TCP/IP). Parameterisation of the instrument and analysis of the data is undertaken using GridVis software included in the delivery. The actual measurement values can be read out using the various field bus protocols (Modbus/RTU, Modbus/TCP, Profibus). An content of the digital inputs and outputs can be used for various.

Data collection and recording

The UMG 511 has an internal 256 MB flash memory for continuous recording of all measured data. The measurement value memory is freely configurable with reference to the measurement values which are to be recorded and the recording intervals. The recording interval is also the average time of the respective measurement value. In addition, the highest and lowest actual values (200ms average time) can also be recorded within the interval if you want to save the data as a graph $y(t)$. Obviously it is also possible to store the measurement data in form of histograms (distribution curve).

The recording of transients and events is initiated by triggers. Transients are recorded from a period larger than 50µs. Events such as excess currents or under/overvoltage can be safely recorded from half a period. Events are recorded with up to 16000 (programmable) half cycles as effective value recorder.

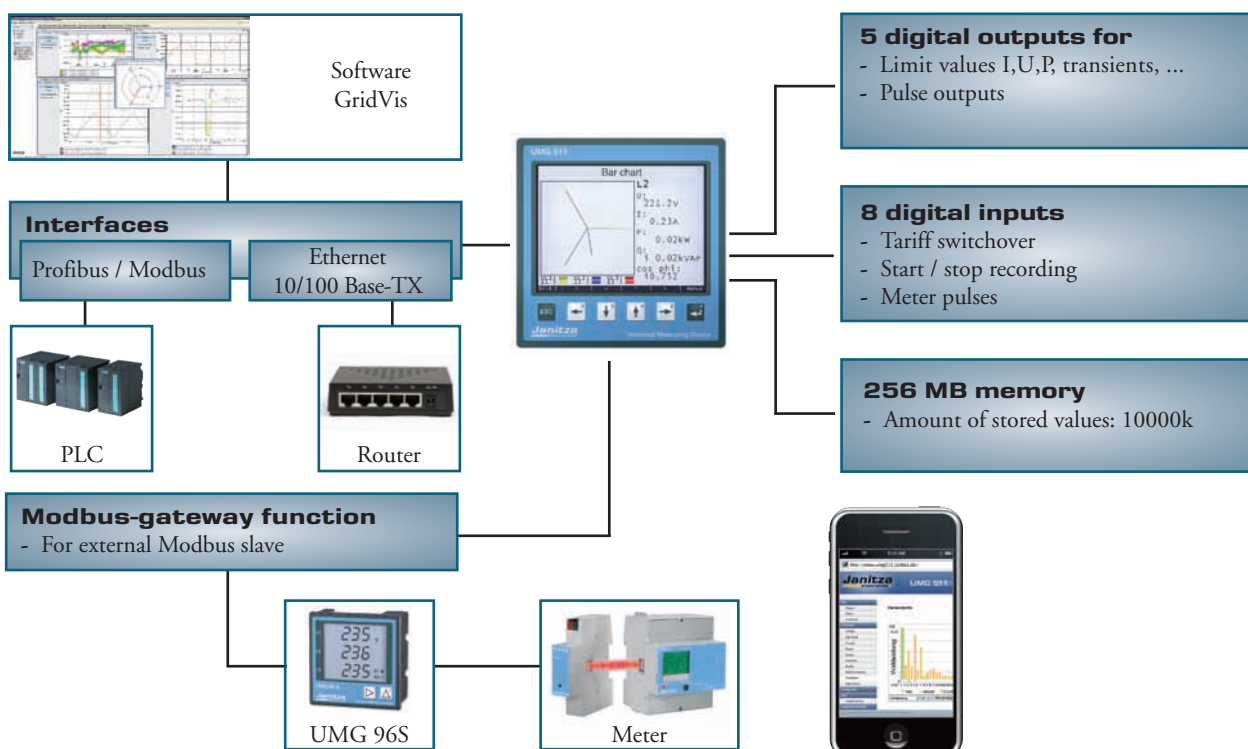

Scope of operation

Dimensional drawings

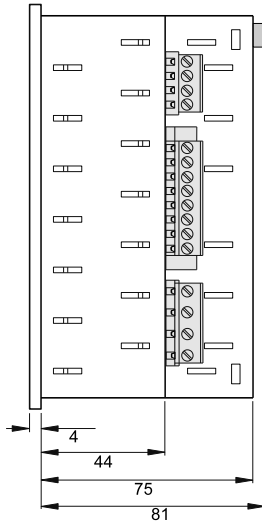

Side view

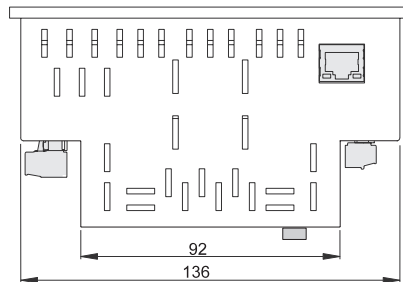

View from below. All measurement data in mm.

Connection illustration

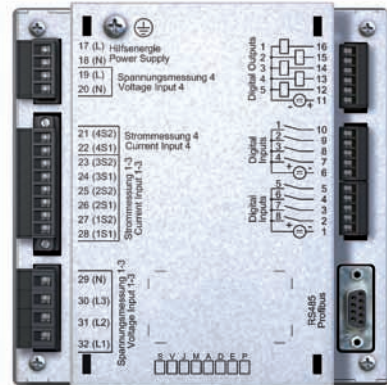

↑ Ethernet connection

Typical connection

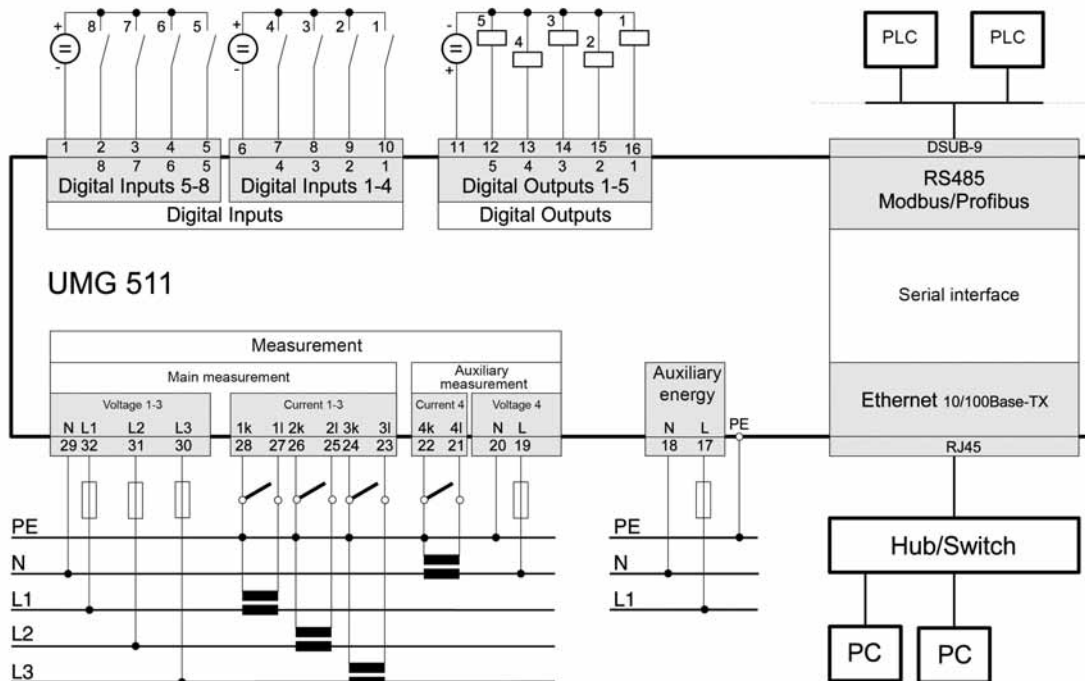

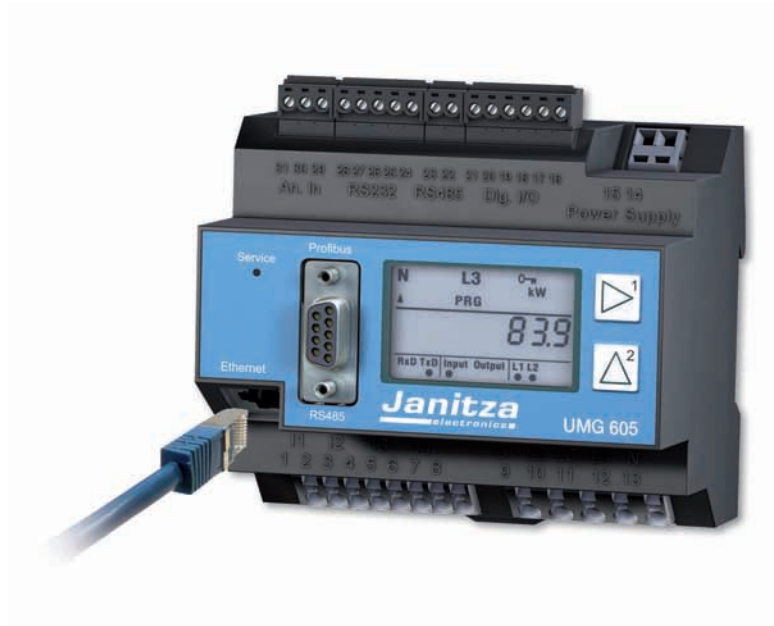

High performance power analyser for DIN rails according to EN 50160

The UMG 605 power quality analyser is particularly suitable for monitoring power quality according to standards such as the EN 50160. All power quality parameters are collected and analysed e.g. flicker, short-term interruptions with fault recorder function, transients, harmonics up to 63rd and inrush currents etc. Extensive communication possibilities e.g. RS 485 Modbus, Profibus, Ethernet (TCP/IP), BACnet, http, FTP, SMTP, SNMP, DNS allow cost effective and rapid integration in existing communication networks. Worldwide access to the embedded web server can be gained through a web browser. The GridVis software included in the content of delivery allows extensive analysis just with the click of a button.

Areas of application

- Continuous monitoring of the power quality e.g. EN 50160
- Ethernet gateway for subordinate measurement points
- Analysis of electrical faults for network problems
- Monitoring of the internal distribution network according to EN 61000-4-7, 4-15, 4-30
- Report generator for EN 50160 analysis
- Control tasks, e.g. depending on achieved measured values or limits
- Transducer for building automation or PLC systems

UMG 605: the extra compact power analyser

Added value through additional functions

Thanks to state-of-the-art digital signal processor, it is possible to offer the power quality analyser UMG 605 at a very reasonable price. The high sampling rate enables a continuous measurement of more than 2000 measured values per measurement cycle (200ms). The UMG 605 power quality analyser serves the purpose of continuous monitoring of the power quality e.g. in accordance with EN 50160. This serves the purpose of monitoring the supply power quality from the energy supply side. The UMG 605 can also be used in applications for failure analysis on the consumer side and is also used as a preventative measure for network perturbations.



Main Features

- Measurement of power quality according to **DIN EN 61000-4-30**
- **Measurement method class A**
- Fourier analysis **1st to 63rd** harmonics for U-LN, U-LL, I, P (consumption/supply) and Q (ind./cap.)
- Measurement of harmonics and interharmonics (U-LN, U-LL, I)
- Analysis and evaluation according to **DIN EN 50160** with the contained programming and analysis software GridVis
- Flicker measurement according to **DIN EN 61000-4-15**
- Measurement in IT and TT grids (300V CATIII)
- 4 voltage measuring inputs, 4 current measuring inputs
- **Continuous sampling** of the voltage and current measuring inputs with **20kHz**
- Recording of more than 2000 different measurement parameters per measuring cycle (200ms)
- Detection of transients $>50\mu\text{s}$ and storage with up to 16.000 samples
- Data logger / event memory (128MB Flashdisk)
- 2 digital inputs and 2 digital outputs
- Profibus DP/V0 alternatively RS 485 (Modbus RTU, Modbus-Master, optional **BACnet**)
- **Ethernet** (Web-Server, E-Mail, optional BACnet)
- Programming of customer specific applications in Jasic

Applications

The power quality analyser which is equipped with 4 current and voltage inputs collects and digitalises the effective values (True RMS) from currents and voltages in 40-70Hz (15-440Hz) networks. The integrated microprocessor calculates the electrical parameters from the sampling values. The relevant voltage can be defined as a phase-neutral or a phase-phase voltage for measurement in a three-phase system. The voltage serves the UMG 605 as a reference voltage for harmonic measurement, transient and event recording and for the flicker meter. A nominal current can be set using this for the measurement of electrical current events. However, it is generally used for measuring the current in the neutral or PE conductor or used for measuring a voltage difference between N and PE.



DIN rail mounting (6TE): reduction of installation costs

Measurement equipment is usually installed in the low voltage main distribution as an integral measurement instrument for the switch-gear cabinet door. Installation and connection costs are significantly reduced by the installation of the UMG 605 on a 35mm DIN rail. This means that the panel cut-out and wiring to the cabinet door is no longer necessary. In order to make use of the extensive functions of modern measuring equipment, the interconnection and central analysis of the data plays an important role. This means that the on-site display generally serves the purpose of the initialisation and service only.

The decidedly compact UMG 605 is suitable for installation in low voltage main distribution panels and machines as well as in installation distribution boards which is particularly of interest for applications in building services engineering, information technology and data centres.

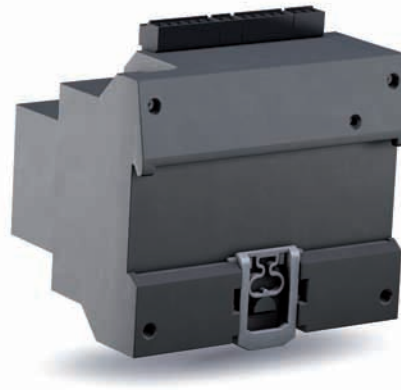

Modern communication architecture through Ethernet: affordable, rapid and safe communication

The costs for installation and communication (e.g. periphery for field buses) often surpass the costs of the measurement devices. By connecting the equipment to an existing Ethernet system, a fast, optimally priced and reliable communication system can be developed. Additional interfaces allow the integration of power analysers in PLC systems or in central building management systems. The use of open architecture offers the user a high amount of flexibility.

Modbus gateway: the affordable connection of units without an Ethernet interface

With the Modbus gateway function, simple Modbus RTU-units can be connected to the Ethernet using the UMG 605. For example, the UMG 605 can be used simultaneously as a gateway for subordinate measurement points or older units which already exist in the installation. Each unit with a Modbus RTU interface, where the data format and function codes match up, can be connected. Data can be marked and scaled.

High-speed Modbus

The device of the UMG 605 series can transfer data between the units using the RS485 interface at a speed of up to 921.5 kB/s.

The e-mail and homepage inform you wherever you are...

Who hasn't experienced it before? You are hardly through the door and the telephone is already ringing. There are problems in production, computers are crashing and the energy supplies are lost. You have direct access to the extremely high performance homepage of the UMG 605 with a web browser and an IP address. Extensive information is already available to you on the homepage. Online data are available together with historical data and graphs recording events. The homepage can be used to directly convert the rates into costs and be exported as a csv file or printed. As an alternative, you can let yourself be informed by e-mail anywhere in the world if your energy supply becomes overloaded, if short-term interruptions to the voltage supplies bring your production processes to a standstill or unauthorised harmonics reduce the lifespan of equipment. The application possibilities are endless.



Scope of operation

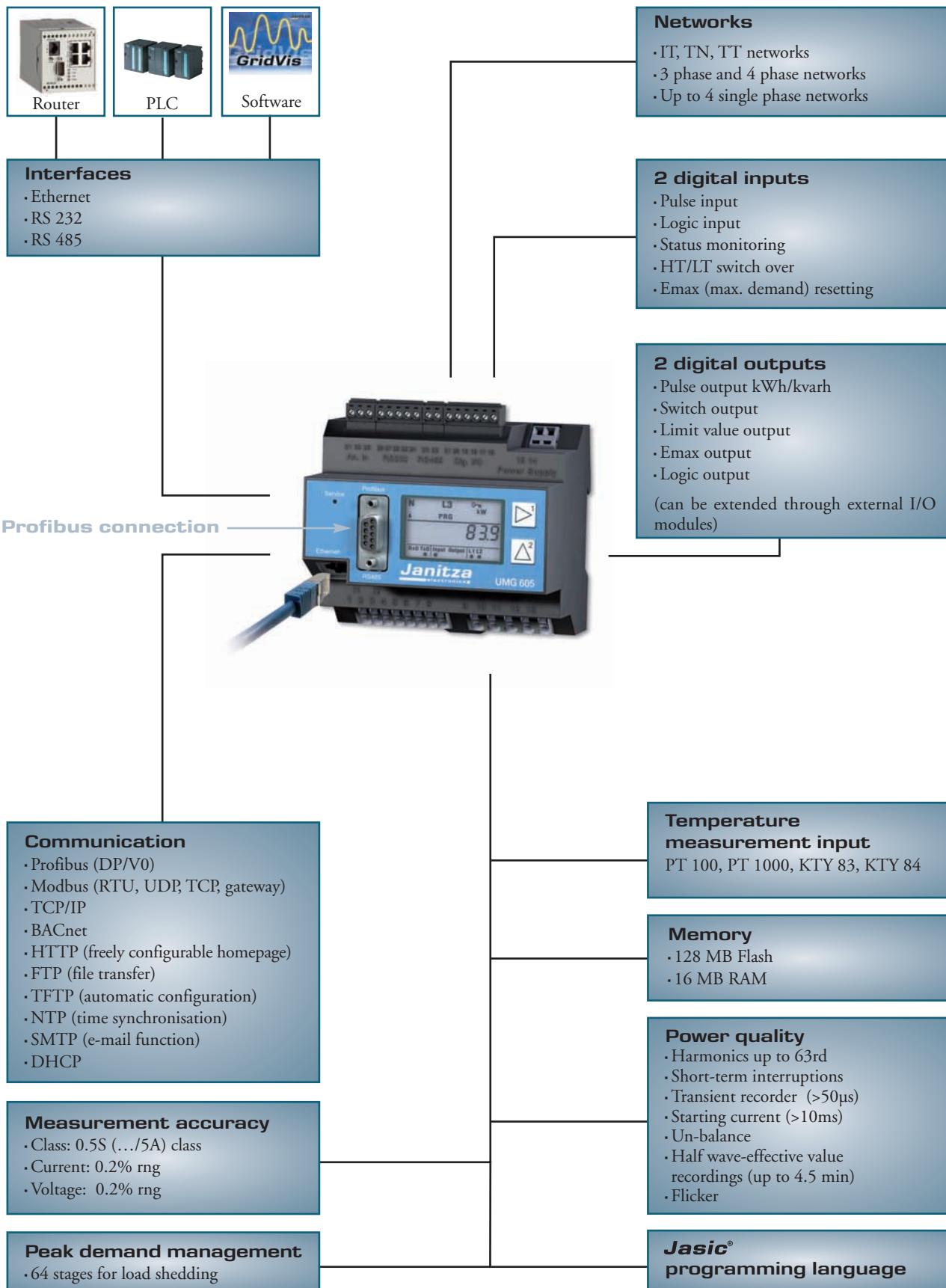



Connection illustration

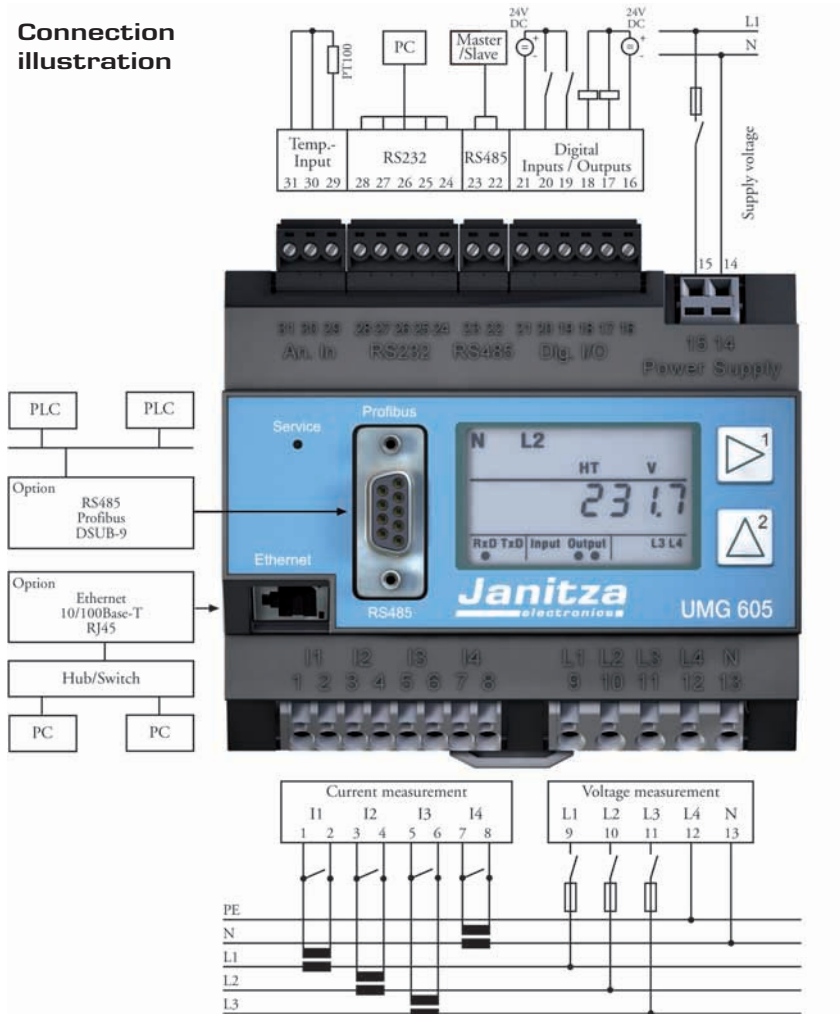

Dimensional drawing

Front view

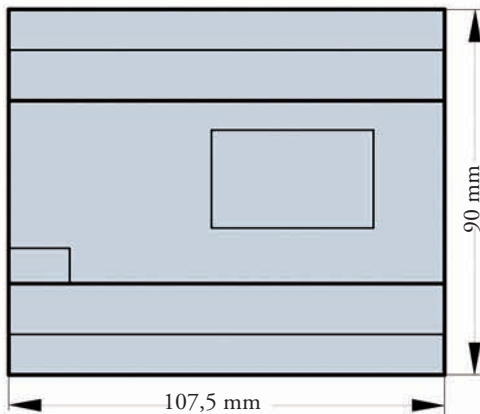

Side view

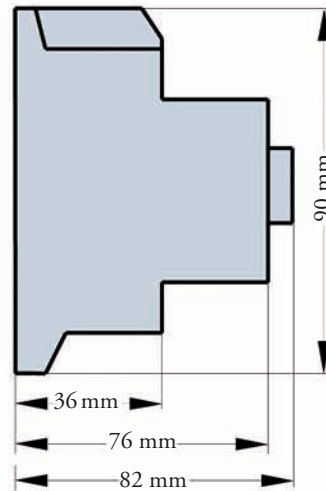

Scope of operation and types of variants

Overview of product variants UMG 511 / UMG 605

Three/four phase power quality analysers; current transformer .../1/5a; including GridVis programming and analysis software

Supply voltage				4 voltage and 4 current inputs	Memory 128/256 MB Flash	digital inputs	digital outputs	1 temperature input	Interfaces				Type	Item number
95...265V AC, 100...370V DC	123...240V AC, 175...340V DC	50...130V AC, 70...180V DC	20...50V AC, 20...70V DC						RS 232	RS 485	Ethernet 100baseT	Profibus DP V0		
●				●	●	8	5	-	-	●	●	●	UMG 511	52.19.001
	●			●	●	2	2	●	●	●	●	●	UMG 605	52.16.027
		●		●	●	2	2	●	●	●	●	●	UMG 605	52.16.028
			●	●	●	2	2	●	●	●	●	●	UMG 605	52.16.029
Options (for all versions)														
Emax function application program (peak demand management)													Emax	52.16.080
BACnet communication													BACnet	52.16.081

- = not possible ● = contained

General technical data

		UMG 511	UMG 605
Supply voltage L-N, AC		Refer to product variant overview	Refer to product variant overview
Overvoltage category		500V CATIII	300V CATIII
Quadrants		4	4
Continuous measurement		yes	yes
8 channel scanning rate	Per channel	20 kHz	20 kHz
Weight		1kg	350g
Dimensions		L=144mm * B=144mm * H=81 mm	L=107,5mm * B=90mm * H=76/82mm
Mounting	According to IEC EN 60999-1/DIN EN 50022	Front panel mounting	35mm DIN rail
Working temperature range		-10...50 °C	-10...55 °C
Connectable conductor (U/I)	Single wire, multi-wire, fine-wire	0,08 - 2,5 mm ²	0,08 - 2,5 mm ²
	pin cable lugs, ferrule	1,5 mm ²	1,5 mm ²
Protection class	According to EN 60529	IP 50 front /IP 20 rear	IP 20

Measurement range

		UMG 511	UMG 605
L-N voltage, AC (without voltage transformer)	Free voltage transformer settings	5 ...500 VAC	5...500 VAC
L-L voltage, AC (without voltage transformer)	Free voltage transformer settings	8...870 VAC	8...870 VAC
Current (transformer: x/1 and x/5A)		0,005..6 A	0,005..6 A
Frequency of mains		40 ..70 Hz	40 ..70 Hz
Networks		TN, TT	IT, TN, TT
Measurement in single/multi-phase networks		1 ph, 2 ph, 3 ph, 4 ph and up to 4 x 1 ph	1 ph, 2 ph, 3 ph, 4 ph and up to 4 x 1 ph

Periphery

		UMG 511	UMG 605
Digital inputs	Status, logic or pulse input	8	2
Digital outputs	Switch logic output or pulse output	5	2
Temperature measurement input	PT100, PT1000, KTY83, KTY84	-	1
Password protection	Multilevel	yes	yes
Demand management	Optional 64 channels	ja	ja
Software	GridVis	ja	ja

Features

		UMG 511	UMG 605
Memory		256 MB	128 MB
Clock		+/- 1 min per month	+/- 1 min per month
Integrated logic		Programming language Jasic®	Programming language Jasic®
Operating hour meter		yes	yes
Weekly time switch		Jasic®	Jasic®

UMG 511 und UMG 605



Measurement values		
Voltage	L1, L2, L3, L4, L1-L2, L2-L3, L1-L3	UMG 511 Accuracy $\pm(0,1\%)$ UMG 605 Accuracy $\pm(0,2\% \text{ rdg} + 0,02\% \text{ rng})$
Current	L1, L2, L3, L4 Calculated sum current	$\pm(0,2\% \text{ rdg} + 0,05\% \text{ rng})$ $\pm(0,6\% \text{ rdg} + 0,05\% \text{ rng})$
K-factor	L1, L2, L3, L4	yes
Three-phase current components	Positive/ Negative/ Zero Phase Sequence	yes
Cos-phi, power factor	L1, L2, L3, L4, Sum L1-L3, Sum L1-L4	yes
Phase angle	L1, L2, L3, L4	yes
Effective energy (kWh)	L1, L2, L3, L4, Sum L1-L3, Sum L1-L4: - Purchased effective energy (tariff 1, tariff 2) - Supplied effective energy (tariff 1, tariff 2)	UMG 511 Class 0,2 (.../5A), UMG 511 Class 0,5S (.../1A), UMG 605 Class 0,5S (.../5A) UMG 605 Class 1 (.../1A)
Reactive energy (kvarh)	L1, L2, L3, L4, Sum L1-L3, Sum L1-L4: - Inductive reactive power (tariff 1, tariff 2) - Capacitive reactive power	Class2
Apparent energy (kVAh)	L1, L2, L3, L4, Sum L1-L3, Sum L1-L4	yes
Current/voltage wave form	L1, L2, L3, L4	yes
Frequency of mains		Accuracy $\pm 0,1\% \text{ rdg}$
Temperature measurement	with UMG 511 not available	Accuracy $\pm 1,5\% \text{ rng}$
Average value		yes
Minimum and maximum values		yes

Power quality		
Harmonics order, 1.- 63rd Harmonics, even/odd	Voltage L1, L2, L3, L4 Measure value > 3% of measuring range Measure value < 3% of measuring range	Accuracy $\pm 5\% \text{ rdg}$ Accuracy $\pm 0,05 \text{ rng}$
Interharmonics	Current, voltage L1, L2, L3, L4	yes
Distortion factor THD-U in %	L1, L2, L3, L4	yes
Distortion factor THD-I in %	L1, L2, L3, L4	yes
Positive/negative/zero system		yes
Actual flicker value	L1, L2, L3, L4	yes
Short term flicker value	L1, L2, L3, L4	yes
Long term flicker value	L1, L2, L3, L4	yes
Transients	50 μs	
Trigger events	10 ms	yes
Inrush currents	10 ms	yes
Event recorder		yes

Communication			
Interfaces		UMG 511	UMG 605
RS 232	9,6, 19,2, 38,4, 115,2 kbps	no	yes
RS 485	9,6, 19,2, 38,4, 76,8, 115,2, 921,6 kbps	yes	yes
Profibus DP	Plug, sub D 9-pole up to 12Mbps	yes	yes
Ethernet 10/100 Base- TX	RJ-45 sockets	yes	yes
Protocols			
Modbus RTU		yes	yes
Profibus DP V0		yes	yes
Modbus TCP		yes	yes
Modbus over TCP		yes	yes
Modbus-Gateway		yes	yes
HTTP	Homepage (configurable)	yes	yes
SMTP	E-Mail	yes	yes
SNTP	Time synchronisation	yes	yes
TFTP	Automatic configuration	yes	yes
FTP	File Transfer	yes	yes
DHCP		yes	yes
BACnet / IP oder MSTP		yes, option	yes, option

Software

The GridVis software is included in the standard content of delivery of the UMG 511 and UMG 605 measurement devices. The software helps you to read out and graphically present measurement data either online as actual values or from the measurement value memory. The data can be displayed as a line graph, bar chart or histogram. The EN 50160 and EN 61000-2-4 analysis tools allow the rapid analysis of both standards. At a glance, it is easier to identify whether the standards are fulfilled throughout the respective measurement period and a copy can be directly created on paper or as a PDF document.

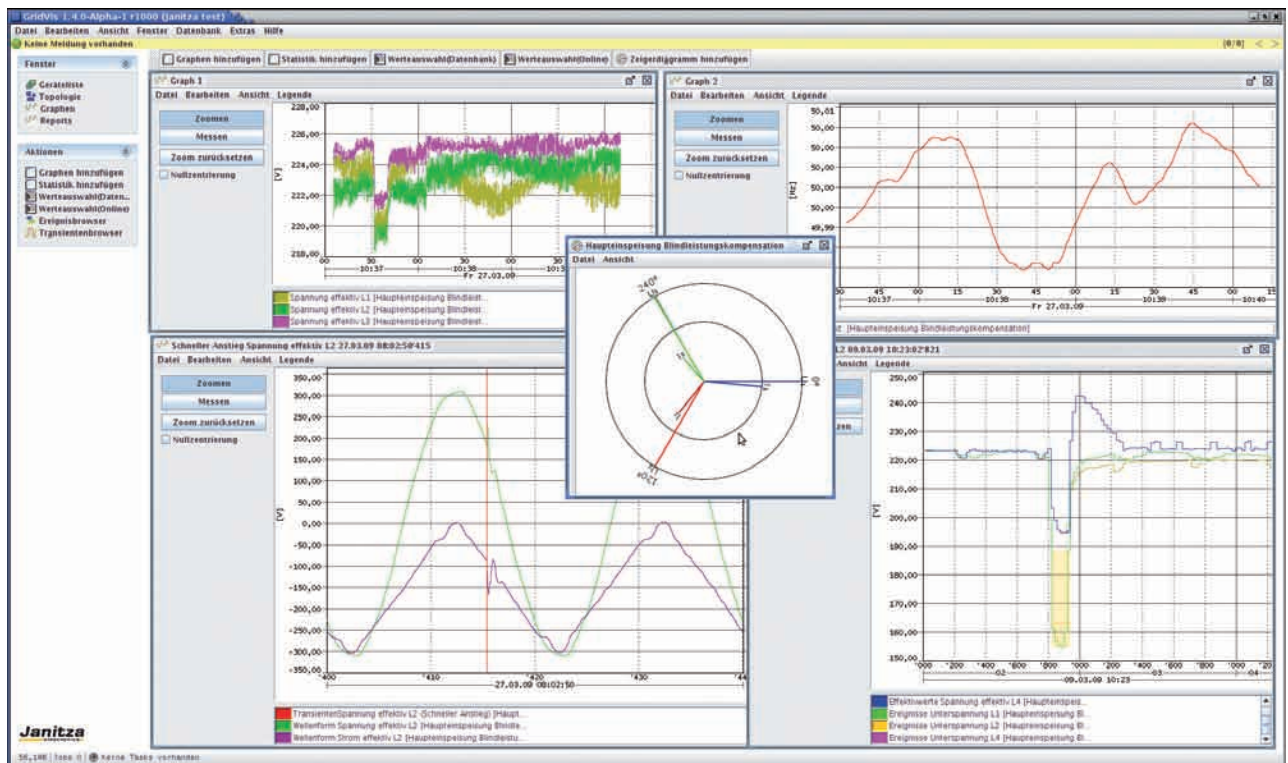

III.: Screenshot GridVis Software with various graphs

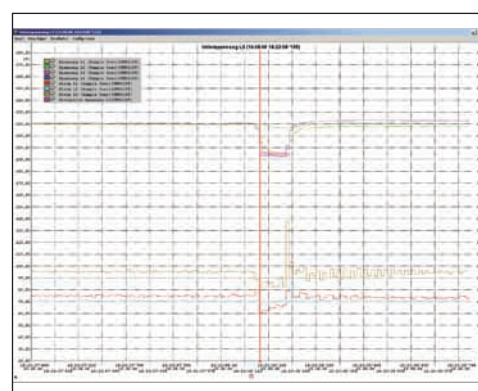
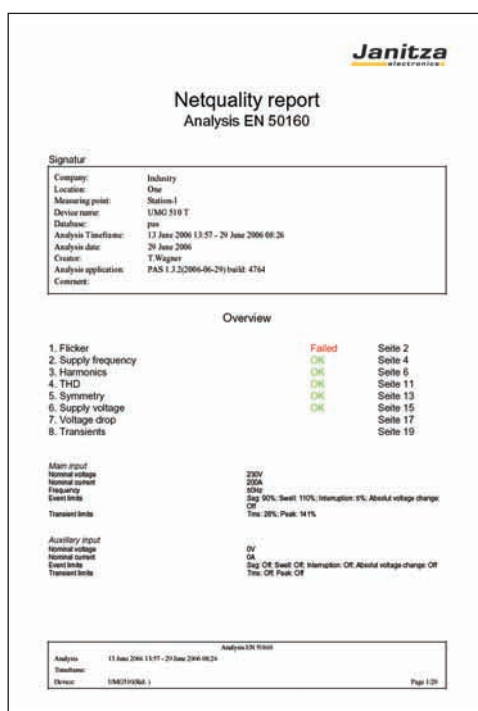

III.: Automatically generated power quality report



Grid visualisation software

The data gained from various measurement points must be collected, saved, visualised and made available. The GridVis software contained in the UMG 605 package allows

- Parameterisation and programming of UMG measurement devices
- Visualisation of the measurement values with topological view
- Automatic download of the measurement data
- Jasic programming
- Data management
- Online analysis tools
- Analysis tools for historic data
- Transient-, event-, flagbrowser

Visualisation, topological view

GridVis allows an individually adaptable visualisation of online data. The topological view provides a rapid overview of energy distribution with the possibility of localising power faults by comparing the individual measurement points and by offering the possibility to monitor the defined tolerances at a glance.

Customer specific solutions can be quickly and simply implemented through uploading of graphic documents (standard formats such as JPG) with circuit diagrams, production lines or construction plans and incorporating the respective measurement units by drag and drop into their actual locations. Limit value excesses (e.g. THD-U is too high) and the status of inputs and outputs can also be displayed.

Online values and analysis of historic data

With the graphic line writer function, GridVis enables rapid online presentation of the selected measurement values. In this function, the graph is continuously expanded with new measurement values. For example, load profiles can be presented through the analysis of historic data in order to produce exact consumption analysis for optimised electricity supply contracts. Fault analysis through the comparison of various parameters can also be achieved with a few mouse clicks.

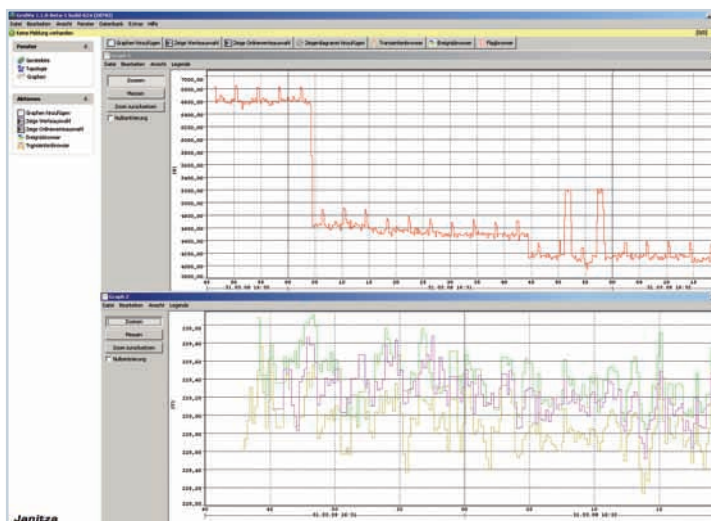

Graphic programming

The graphic programming option for user programs is completely new in the field of digital power analysers. Programs specific to the application can be created with this method such as the free programming of inputs and outputs, monitoring of processes or the issue of reports when defined limit values are achieved. In addition to the operator-friendly graphic programming, the user is also free to program the Jasic® source code directly.

Jasic® programming language

The Jasic® programming language offers brand new opportunities. The user is no longer tied to the functions which are fixed integrations in the unit; the unit can be expanded to include more functions. Up to seven of these freely definable user programs can be processed simultaneously in the UMG devices.

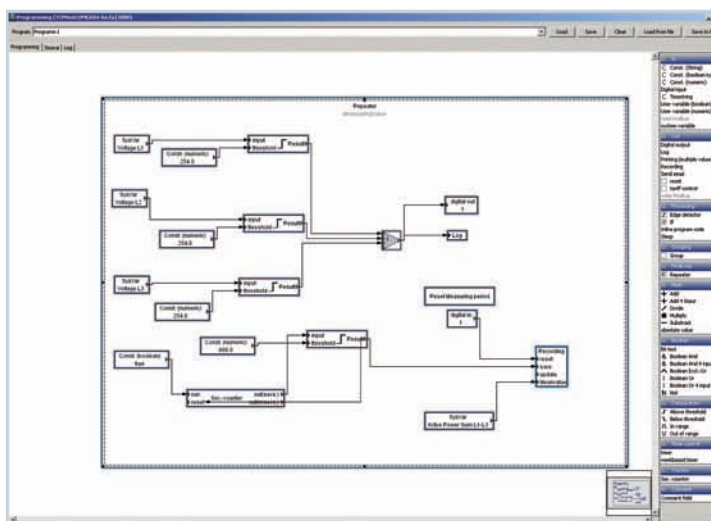

Ill.: Graphical programming

Item no.: 33.03.636 04/2009

Representative

Janitza
electronics

Janitza electronics GmbH
Vor dem Polstück 1
D-35633 Lahnau
Germany
Tel.: 0049 (0) 6441 9642-0
Fax: 0049 (0) 6441 9642-30
info@janitza.de
www.janitza.de